

Keysight 2-Port and 4-Port PNA Network Analyzer

N5227A 10 MHz to 67 GHz

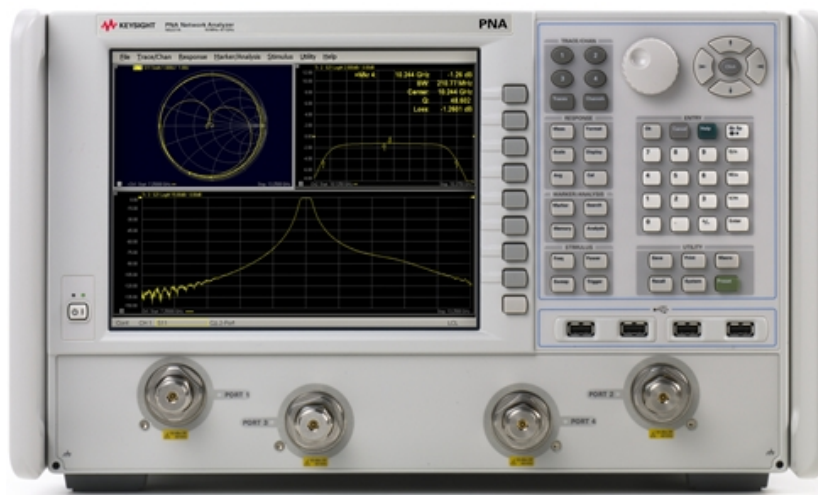

Data Sheet
and Technical
Specifications for
Option 210 and 410

Documentation Warranty

THE MATERIAL CONTAINED IN THIS DOCUMENT IS PROVIDED "AS IS," AND IS SUBJECT TO BEING CHANGED, WITHOUT NOTICE, IN FUTURE EDITIONS. FURTHER, TO THE MAXIMUM EXTENT PERMITTED BY APPLICABLE LAW, KEYSIGHT DISCLAIMS ALL WARRANTIES, EITHER EXPRESS OR IMPLIED WITH REGARD TO THIS MANUAL AND ANY INFORMATION CONTAINED HEREIN, INCLUDING BUT NOT LIMITED TO THE IMPLIED WARRANTIES OF MERCHANTABILITY AND FITNESS FOR A PARTICULAR PURPOSE. KEYSIGHT SHALL NOT BE LIABLE FOR ERRORS OR FOR INCIDENTAL OR CONSEQUENTIAL DAMAGES IN CONNECTION WITH THE FURNISHING, USE, OR PERFORMANCE OF THIS DOCUMENT OR ANY INFORMATION CONTAINED HEREIN. SHOULD KEYSIGHT AND THE USER HAVE A SEPARATE WRITTEN AGREEMENT WITH WARRANTY TERMS COVERING THE MATERIAL IN THIS DOCUMENT THAT CONFLICT WITH THESE TERMS, THE WARRANTY TERMS IN THE SEPARATE AGREEMENT WILL CONTROL.

U.S. Government Rights

U.S. Government Rights. The Software is "commercial computer software," as defined by Federal Acquisition Regulation ("FAR") 2.101. Pursuant to FAR 12.212 and 27.405-3 and Department of Defense FAR Supplement ("DFARS") 227.7202, the U.S. government acquires commercial computer software under the same terms by which the software is customarily provided to the public. Accordingly, Keysight provides the Software to U.S. government customers under its standard commercial license, which is embodied in its End User License Agreement (EULA), a copy of which can be found at <http://www.keysight.com/find/sweula>. The license set forth in the EULA represents the exclusive authority by which the U.S. government may use, modify, distribute, or disclose the Software. The EULA and the license set forth therein, does not require or permit, among other things, that Keysight: (1) Furnish technical information related to commercial computer software or commercial computer software documentation that is not customarily provided to the public; or (2) Relinquish to, or otherwise provide, the government rights in excess of these rights customarily provided to the public to use, modify, reproduce, release, perform, display, or disclose commercial computer software or commercial computer software documentation. No additional government requirements beyond those set forth in the EULA shall apply, except to the extent that those terms, rights, or licenses are explicitly required from all providers of commercial computer software pursuant to the FAR and the DFARS and are set forth specifically in writing elsewhere in the EULA. Keysight shall be under no obligation to update, revise or otherwise modify the Software. With respect to any technical data as defined by FAR 2.101, pursuant to FAR 12.211 and 27.404.2 and DFARS 227.7102, the U.S. government acquires no greater than Limited Rights as defined in FAR 27.401 or DFAR 227.7103-5 (c), as applicable in any technical data.

| | |
|---|-----------|
| U.S. Government Rights | 2 |
| Definitions..... | 5 |
| Corrected System Performance | 6 |
| System Dynamic Range and Receiver Dynamic Range | 6 |
| Table 1. System Dynamic Range and Receiver Dynamic Range, Option 210, 410 | 7 |
| N5227A Corrected System Performance, Option 210, 410..... | 8 |
| Table 2a. N5227A with 85058B Calibration Kit..... | 8 |
| Table 2b. N5227A with N4694A 2-Port Electronic Calibration Module..... | 10 |
| Uncorrected System Performance | 12 |
| Table 3a. Error Terms (dB), All Ports, Option 210, 410 - Specifications..... | 12 |
| Table 3b. Error Terms (dB), All Ports, Option 210, 410 - Typical | 13 |
| Test Port Output | 13 |
| Table 4. Frequency Information, Option 210, 410 | 13 |
| Table 5. Maximum Leveled Power (dBm) - Option 210, 410 | 14 |
| Table 6. Power Level Accuracy (dB), Option 210, 410..... | 15 |
| Table 7a. Power Level Linearity (dB), Option 210, 410 - Specification..... | 15 |
| Table 7b. Power Level Linearity (dB), Option 210, 410 - Specification..... | 16 |
| Table 8. Power Sweep Range (dB) – Option 210, 410 | 16 |
| Table 9. Nominal (Preset) Power (dBm) | 17 |
| Table 10. Power Resolution and Maximum/Minimum Settable Power, Option 210, 410..... | 17 |
| Table 11. 2 nd and 3 rd Harmonics at Max Specified Power (dBc), Option 210, 410 | 17 |
| Table 12. Non-Harmonic Spurs at Nominal Power (dBc), Option 210, 410 - Typical..... | 18 |
| Table 13. Phase Noise (dBc/Hz), Option 210, 410 - Typical..... | 18 |
| Test Port Input | 19 |
| Table 14. Test Port Noise Floor (dBm) @ 10 Hz IFBW, Option 210, 410 | 19 |
| Table 15. 0.1 dB Receiver Compression at Test Port (dBm), Option 210, 410 | 19 |
| Table 16. Receiver Compression at Test Port Power - Specification..... | 20 |
| Table 17. N5227A Trace Noise Magnitude (dB rms)..... | 20 |
| Table 18. N5227A Trace Noise Phase (deg rms)..... | 21 |
| Table 19. Reference Level Magnitude, Option 210, 410 - Specification | 21 |
| Table 20. Stability vs. Temperature, Option 210, 410 - Typical..... | 22 |
| Table 21. Stability vs. Time, Option 210, 410 – Specification..... | 22 |
| Table 22. Damage Input Level, Option 210, 410..... | 23 |
| Dynamic Accuracy | 23 |
| Table 23. N5227A Dynamic Accuracy | 23 |

| | |
|---|-----------|
| Table 24. Group Delay - Typical..... | 28 |
| General Information | 29 |
| Table 25. Miscellaneous Information..... | 29 |
| Table 26. Front Panel Information, Option 210, 410 | 29 |
| Table 26. (Continued) Front Panel Information, Option 210, 410 | 30 |
| Table 27. Rear Panel Information, Option 210, 410..... | 30 |
| Table 27. (Continued) Rear Panel Information, Option 210, 410..... | 31 |
| Table 27. (Continued) Rear Panel Information, Option 210, 410..... | 32 |
| Table 27. (Continued) Rear Panel Information, Option 210, 410..... | 33 |
| Table 28. Analyzer Dimensions and Weight..... | 34 |
| Regulatory and Environmental Information | 34 |
| Measurement Throughput Summary | 35 |
| Table 29. Typical Cycle Time (ms) for Measurement Completion, All Models and Options..... | 35 |
| Table 30. Typical Cycle Time (ms) for Full-Span Measurement Completion..... | 36 |
| Table 31. Cycle Time vs. IF Bandwidth - Typical | 36 |
| Table 32. Cycle Time vs. Number of Points - Typical..... | 37 |
| Table 33. Data Transfer Time (ms) - Typical | 38 |
| Test Set Block Diagrams..... | 39 |
| N5227A Option 210 (2-port metrology configuration)..... | 39 |
| N5227A Option 410 (4-port metrology configuration)..... | 39 |
| Receiver Block Diagram..... | 40 |

This is a complete list of the technical specifications for the N5227A PNA network analyzer with the following options:

2-Port Model

Option 210 - 2-port, single source, with metrology configuration

4-Port Model

Option 410 - 4-port, dual source, with metrology configuration

See block diagrams for all models and options beginning on page 38.

Notes

This document provides technical specifications for the 85058B and N4694A calibration kits.

Please download our free Uncertainty Calculator from http://www.keysight.com/find/na_calculator to generate the curves for your calibration kit and PNA setup.

Typical performance information between 67 GHz and 70 GHz is shown in this document where available. The performance is degraded at particular frequencies in this range due to the modes of the 1.85 mm connectors used in the analyzer, test port cables and adapters.

For all tables in this data sheet, the specified performance at the exact frequency of a break is the degraded value of the two specifications at that frequency.

Definitions

All specifications and characteristics apply over a 25 °C ±5 °C range (unless otherwise stated) and 90 minutes after the instrument has been turned on.

Specification (spec.): Warranted performance. Specifications include guardbands to account for the expected statistical performance distribution, measurement uncertainties, and changes in performance due to environmental conditions.

Characteristic (char.): A performance parameter that the product is expected to meet before it leaves the factory, but that is not verified in the field and is not covered by the product warranty. A characteristic includes the same guardbands as a specification.

Typical (typ.): Expected performance of an average unit which does not include guardbands. It is not covered by the product warranty.

Nominal (nom.): A general, descriptive term that does not imply a level of performance. It is not covered by the product warranty.

Calibration: The process of measuring known standards to characterize a network analyzer's systematic (repeatable) errors.

Corrected (residual): Indicates performance after error correction (calibration). It is determined by the quality of calibration standards and how well "known" they are, plus system repeatability, stability, and noise.

Uncorrected (raw): Indicates instrument performance without error correction. The uncorrected performance affects the stability of a calibration.

Standard: When referring to the analyzer, this includes no options unless noted otherwise.

Corrected System Performance

The specifications in this section apply for measurements made with the N5227A PNA network analyzer with the following conditions:

- 10 Hz IF bandwidth
- No averaging applied to data
- Isolation calibration with an averaging factor of 8

System Dynamic Range and Receiver Dynamic Range

- **System Dynamic Range** is defined as the specified source maximum output power (spec) minus the noise floor (spec).
- **Receiver Dynamic Range** is defined as the test port compression at 0.1 dB (typical) minus the noise floor (typical).

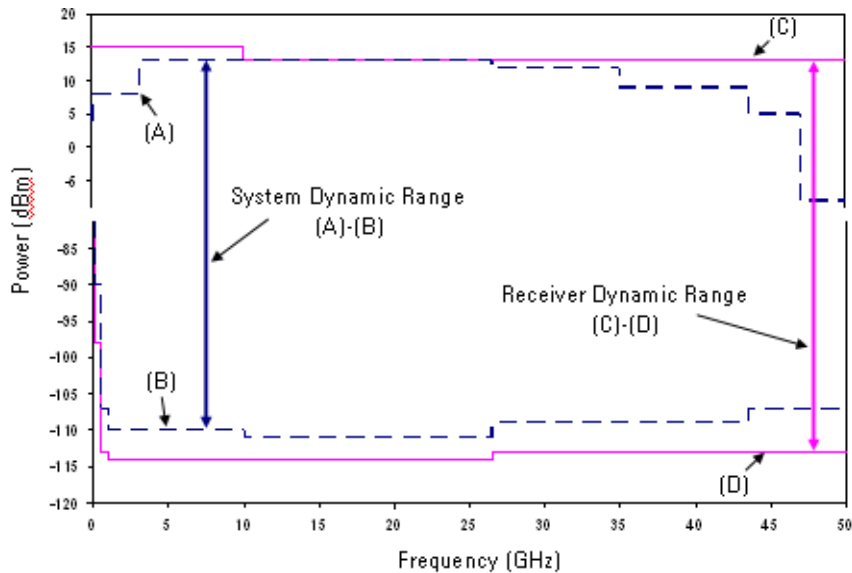

NOTE

The effective dynamic range must take measurement uncertainties and interfering signals into account. This set-up should only be used when the receiver input will never exceed its maximum receiver input. When the analyzer is in segment sweep mode, it can have predefined frequency segments which will output a higher power level when the extended dynamic range is required (i.e. devices with high insertion loss), and reduced power when the maximum receiver input level will occur (i.e. devices with low insertion loss). The extended range is only available in one-path transmission measurements.

It may typically be degraded at particular frequencies below 500 MHz due to spurious receiver residuals.

Table 1. System Dynamic Range and Receiver Dynamic Range, Option 210, 410

| Description | Specification | | | Typical | | | |
|--------------------|-----------------------------------|------------------------------------|---------------------------------|---------------------------|-------------------------------------|---|---------------------------------|
| | System Dynamic Range (dB) (A)-(B) | Max Leveled Output Power (dBm) (A) | Test Port Noise Floor (dBm) (B) | System Dynamic Range (dB) | Receiver Dynamic Range (dB) (C)-(D) | 0.1 dB Compression at Test Port (dBm) (C) | Test Port Noise Floor (dBm) (D) |
| 10 MHz to 50 MHz | 76 | 6 | -70 | 90 | 91 | 15 | -76 |
| 50 MHz to 100 MHz | 99 | 7 | -92 | 111 | 112 | 15 | -97 |
| 100 MHz to 500 MHz | 108 | 7 | -101 | 120 | 118 | 12 | -106 |
| 500 MHz to 1 GHz | 117 | 7 | -110 | 130 | 127 | 12 | -115 |
| 1 GHz to 2 GHz | 121 | 7 | -114 | 133 | 131 | 12 | -119 |
| 2 GHz to 3.2 GHz | 121 | 7 | -114 | 131 | 131 | 12 | -119 |
| 3.2 GHz to 10 GHz | 121 | 7 | -114 | 132 | 131 | 12 | -119 |
| 10 GHz to 13.5 GHz | 120 | 6 | -114 | 132 | 132 | 12 | -120 |
| 13.5 GHz to 16 GHz | 122 | 6 | -116 | 134 | 133 | 12 | -121 |
| 16 GHz to 19 GHz | 121 | 5 | -116 | 132 | 133 | 12 | -121 |
| 19 GHz to 20 GHz | 121 | 5 | -116 | 132 | 133 | 12 | -121 |
| 20 GHz to 24 GHz | 121 | 5 | -116 | 131 | 133 | 12 | -121 |
| 24 GHz to 26.5 GHz | 122 | 5 | -117 | 130 | 133 | 12 | -121 |
| 26.5 GHz to 30 GHz | 110 | 4 | -106 | 121 | 124 | 12 | -112 |
| 30 GHz to 32 GHz | 109 | 3 | -106 | 120 | 123 | 11 | -112 |
| 32 GHz to 35 GHz | 110 | 4 | -106 | 121 | 123 | 11 | -112 |
| 35 GHz to 40 GHz | 103 | -1 | -104 | 117 | 121 | 11 | -110 |
| 40 GHz to 43.5 GHz | 106 | 5 | -101 | 114 | 119 | 11 | -108 |
| 43.5 GHz to 50 GHz | 106 | 5 | -101 | 115 | 119 | 11 | -108 |
| 50 GHz to 60 GHz | 106 | 5 | -101 | 114 | 118 | 11 | -107 |
| 60 GHz to 64 GHz | 106 | 5 | -101 | 115 | 119 | 11 | -108 |
| 64 GHz to 67 GHz | 106 | 5 | -101 | 116 | 119 | 11 | -108 |
| 67 GHz to 70 GHz | -- | -- | -- | 114 | 117 | 11 | -106 |

N5227A Corrected System Performance, Option 210, 410

For any S_{ii} reflection measurement:

- $S_{jj} = 0$.

For any S_{ij} transmission measurement:

- $S_{ji} = S_{ij}$ when $S_{ij} \leq 1$
- $S_{ji} = 1/S_{ij}$ when $S_{ij} > 1$
- $S_{kk} = 0$ for all k

Applies to the N5227A Option 210 or 410 analyzers, N4697F flexible test port cable set, and a full 2-port calibration. Also applies to the following condition:

Environmental temperature $23^\circ \pm 3^\circ \text{C}$, with $< 1^\circ \text{C}$ deviation from calibration temperature

Table 2a. N5227A with 85058B Calibration Kit

| Description | Specification (dB) | | | | | | | |
|-----------------------|------------------------|-----------------------|-----------------------|------------------------|------------------------|------------------------|------------------------|------------------------|
| | 10 MHz to 50 MHz | 50 MHz to 2 GHz | 2 GHz to 10 GHz | 10 GHz to 20 GHz | 20 GHz to 35 GHz | 35 GHz to 50 GHz | 50 GHz to 60 GHz | 60 GHz to 67 GHz |
| Directivity | 35 | 35 | 41 | 38 | 37 | 37 | 34 | 34 |
| Source Match | 34 | 34 | 44 | 40 | 41 | 42 | 40 | 40 |
| Load Match | 35 | 35 | 41 | 38 | 36 | 37 | 33 | 33 |
| Reflection Tracking | | | | | | | | |
| Mag | 0.019 | 0.019 | 0.010 | 0.033 | 0.033 | 0.020 | 0.030 | 0.030 |
| Phase (degree) | 0.125 | 0.125 | 0.066 | 0.218 | 0.218 | 0.132 | 0.198 | 0.198 |
| Transmission Tracking | | | | | | | | |
| Mag | 0.036 | 0.033 | 0.016 | 0.037 | 0.058 | 0.058 | 0.093 | 0.100 |
| Phase (degree) | 0.234 | 0.219 | 0.108 | 0.242 | 0.381 | 0.383 | 0.612 | 0.658 |

Transmission Uncertainty

Magnitude

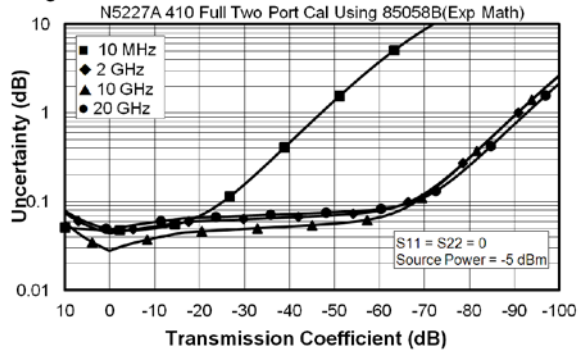

Phase

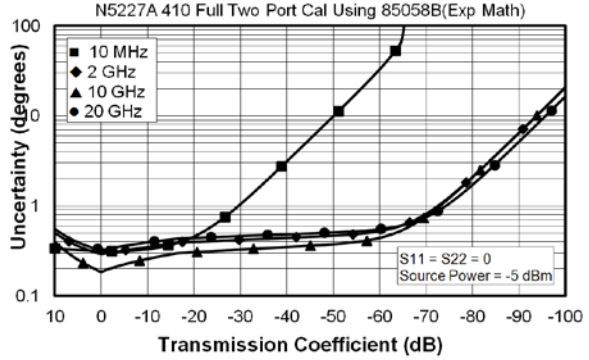

Magnitude

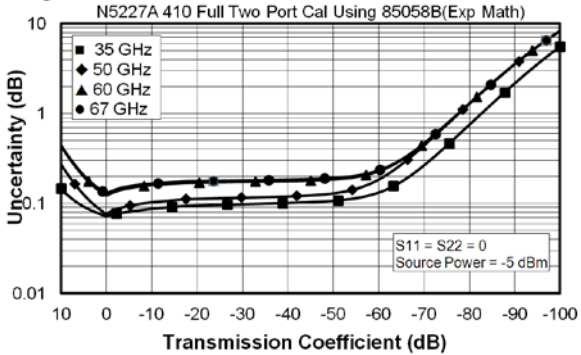

Phase

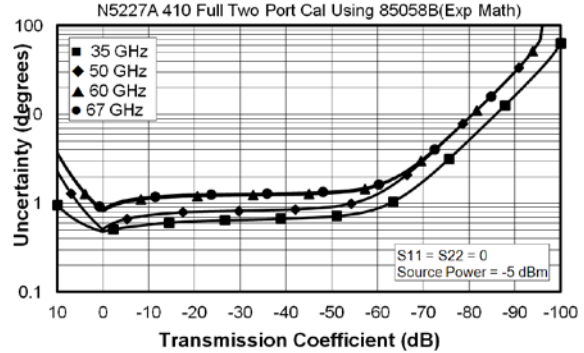

Reflection Uncertainty

Magnitude

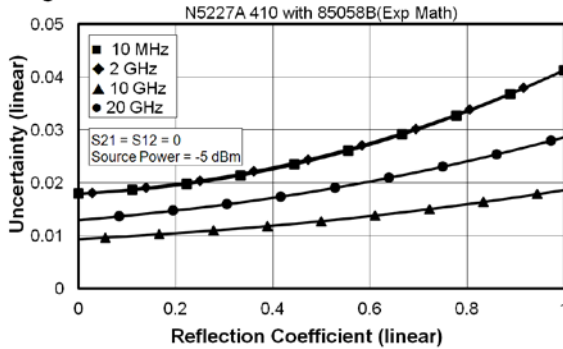

Phase

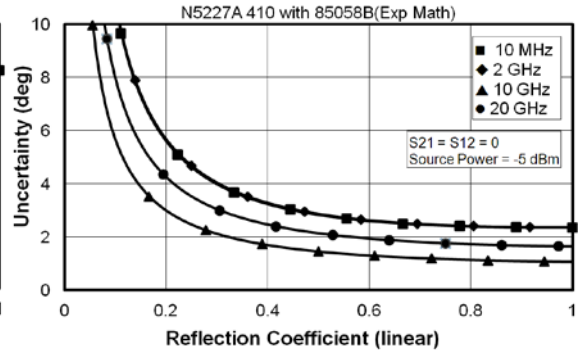

Magnitude

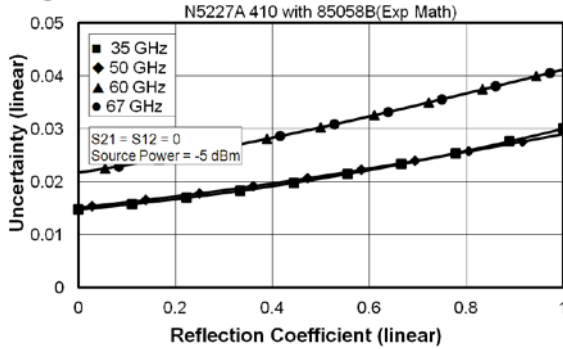

Phase

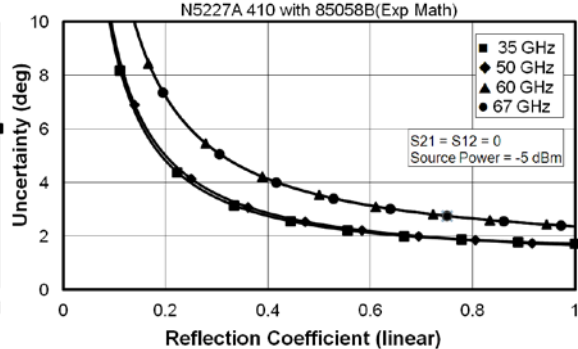
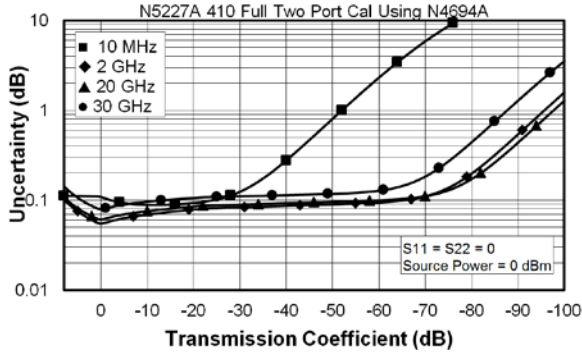

Table 2b. N5227A with N4694A 2-Port Electronic Calibration Module

| Description | Specification (dB) | | | | | | | |
|-----------------------|------------------------|-----------------------|-----------------------|------------------------|------------------------|------------------------|------------------------|------------------------|
| | 10 MHz to 50 MHz | 50 MHz to 2 GHz | 2 GHz to 20 GHz | 20 GHz to 30 GHz | 30 GHz to 40 GHz | 40 GHz to 50 GHz | 50 GHz to 60 GHz | 60 GHz to 67 GHz |
| Directivity | 33 | 41 | 47 | 46 | 44 | 42 | 41 | 38 |
| Source Match | 25 | 38 | 39 | 35 | 34 | 33 | 30 | 27 |
| Load Match | 25 | 38 | 38 | 34 | 33 | 32 | 29 | 26 |
| Reflection Tracking | | | | | | | | |
| Mag | ±0.050 | ±0.040 | ±0.040 | ±0.050 | ±0.060 | ±0.070 | ±0.080 | ±0.090 |
| Phase (degree) | ±0.330 | ±0.264 | ±0.264 | ±0.330 | ±0.396 | ±0.462 | ±0.528 | ±0.594 |
| Transmission Tracking | | | | | | | | |
| Mag | ±0.074 | ±0.045 | ±0.049 | ±0.064 | ±0.077 | ±0.092 | ±0.110 | ±0.133 |
| Phase (degree) | ±0.490 | ±0.296 | ±0.321 | ±0.420 | ±0.509 | ±0.605 | ±0.729 | ±0.878 |

Transmission Uncertainty

Magnitude



Phase

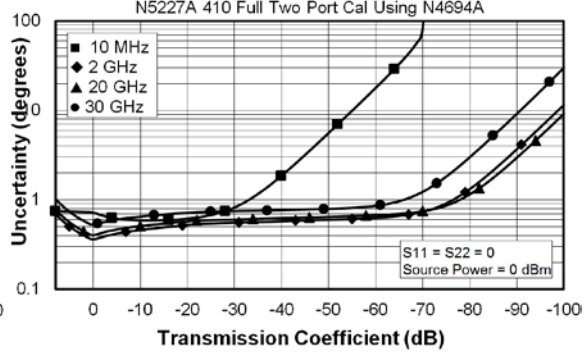

Magnitude

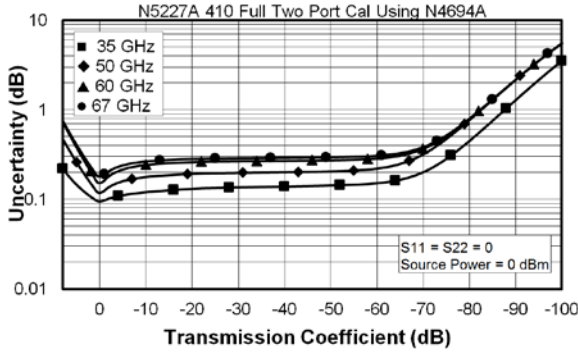

Phase

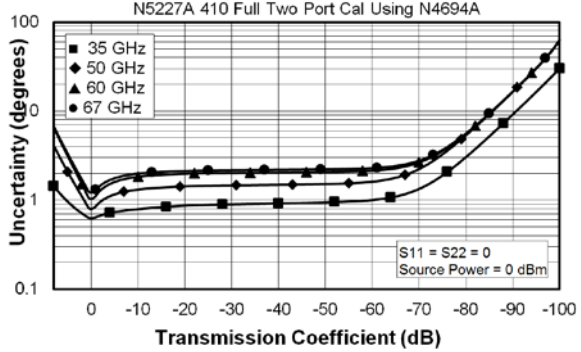

Reflection Uncertainty

Magnitude

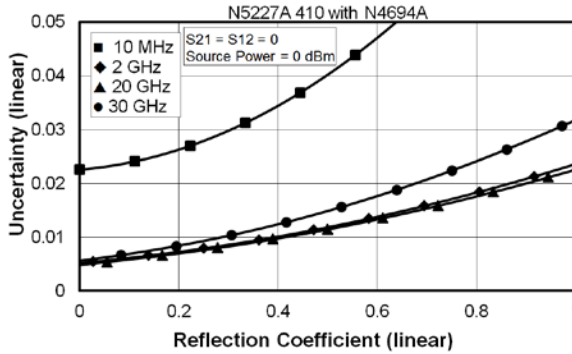

Phase

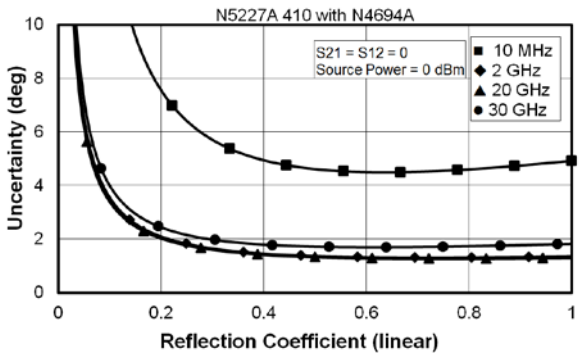

Magnitude

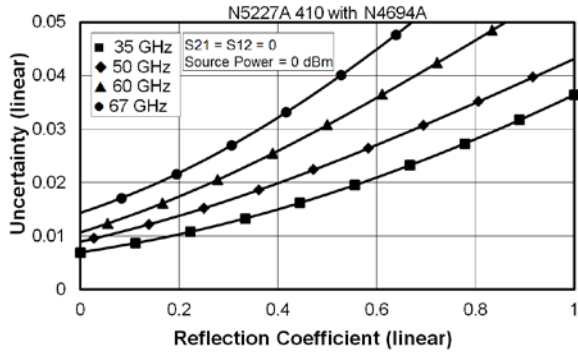

Phase

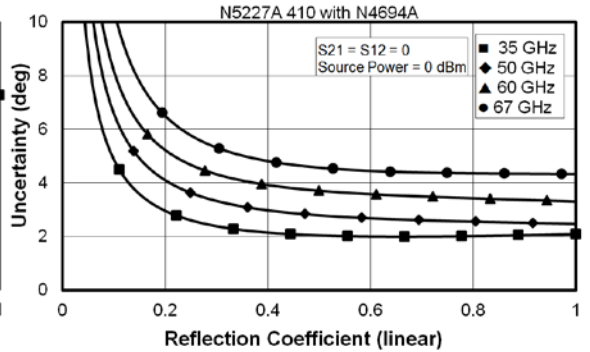

Uncorrected System Performance

Specifications apply to following conditions:

- Over environmental temperature of 25 °C ±5 °C, with less than 1°C variation from the calibration temperature.
- Cable loss not included in Transmission Tracking.
- Crosstalk measurement conditions: normalized to a thru, measured with shorts on all ports, 10 Hz IF bandwidth, averaging factor of 8, alternate mode, source power set to the specified maximum power.

Table 3a. Error Terms (dB), All Ports, Option 210, 410 - Specifications

| | Directivity | Source Match | Load Match | Transmission Tracking | Reflection Tracking | Crosstalk |
|----------------------|-------------|--------------|------------|-----------------------|---------------------|-----------|
| 10 MHz to 50 MHz | 17 | 21 | 18 | -- | -- | -- |
| 50 MHz to 200 MHz | 24 | 30 | 24 | -- | -- | -- |
| 200 MHz to 500 MHz | 24 | 29 | 23 | | | |
| 500 MHz to 2 GHz | 24 | 21 | 19 | -- | -- | -- |
| 2 GHz to 3.2 GHz | 20 | 21 | 19 | | | |
| 3.2 GHz to 10 GHz | 20 | 19 | 17 | -- | -- | -- |
| 10 GHz to 13.5 GHz | 16 | 19 | 15 | -- | -- | -- |
| 13.5 GHz to 16 GHz | 16 | 19 | 13 | | | |
| 16 GHz to 20 GHz | 16 | 16 | 13 | -- | -- | -- |
| 20 GHz to 24 GHz | 14 | 14 | 12 | | | |
| 24 GHz to 26.5 GHz | 14 | 13 | 12 | | | |
| 26.5 GHz to 43.5 GHz | 13 | 12 | 10 | -- | -- | -- |
| 43.5 GHz to 46 GHz | 13 | 11 | 10 | | | |
| 46 GHz to 50 GHz | 13 | 11 | 10 | | | |
| 50 GHz to 60 GHz | 13 | 10 | 8 | -- | -- | -- |
| 60 GHz to 67 GHz | 10 | 9 | 8 | -- | -- | -- |
| 67 GHz to 70 GHz | -- | -- | -- | -- | -- | -- |

Table 3b. Error Terms (dB), All Ports, Option 210, 410 - Typical

| | Directivity | Source Match | Load Match | Transmission Tracking | Reflection Tracking | Crosstalk |
|----------------------|-------------|--------------|------------|-----------------------|---------------------|-----------|
| 10 MHz to 50 MHz | 20 | 29 | 25 | +/- 1.0 | +/- 1.0 | -90 |
| 50 MHz to 200 MHz | 28 | 38 | 32 | +/- 1.0 | +/- 1.0 | -109 |
| 200 MHz to 500 MHz | 28 | 35 | 31 | +/- 1.0 | +/- 1.0 | -123 |
| 500 MHz to 2 GHz | 31 | 27 | 25 | +/- 1.0 | +/- 1.0 | -124 |
| 2 GHz to 3.2 GHz | 28 | 27 | 25 | +/- 1.0 | +/- 1.0 | -124 |
| 3.2 GHz to 10 GHz | 25 | 24 | 23 | +/- 1.0 | +/- 1.0 | -124 |
| 10 GHz to 13.5 GHz | 23 | 25 | 21 | +/- 1.0 | +/- 1.0 | -124 |
| 13.5 GHz to 16 GHz | 23 | 26 | 21 | +/- 1.0 | +/- 1.0 | -124 |
| 16 GHz to 20 GHz | 20 | 21 | 19 | +/- 1.0 | +/- 1.0 | -124 |
| 20 GHz to 24 GHz | 18 | 19 | 18 | +/- 1.0 | +/- 1.0 | -124 |
| 24 GHz to 26.5 GHz | 18 | 19 | 17 | +/- 1.0 | +/- 1.0 | -124 |
| 26.5 GHz to 43.5 GHz | 16 | 17 | 16 | +/- 1.0 | +/- 1.0 | -115 |
| 43.5 GHz to 46 GHz | 19 | 16 | 15 | +/- 1.0 | +/- 1.0 | -113 |
| 46 GHz to 50 GHz | 19 | 16 | 16 | +/- 1.0 | +/- 1.0 | -113 |
| 50 GHz to 60 GHz | 16 | 14 | 14 | +/- 1.0 | +/- 1.0 | -113 |
| 60 GHz to 67 GHz | 16 | 13 | 14 | +/- 1.0 | +/- 1.0 | -113 |
| 67 GHz to 70 GHz | 15 | 11 | 11 | +/- 1.0 | +/- 1.5 | -110 |

Test Port Output

Table 4. Frequency Information, Option 210, 410

| Description | Specification | Typical |
|------------------------|------------------|---|
| N5227A Frequency Range | 10 MHz to 67 GHz | 67 GHz to 70 GHz |
| Frequency Resolution | 1 Hz | -- |
| Frequency Accuracy | +/- 1 ppm | -- |
| Frequency Stability | -- | +/-0.05 ppm, -10° to 70° C ¹ +/-0.1 ppm/yr maximum ² |

¹ Assumes no variation in time.

² Assumes no variation in temperature.

Table 5. Maximum Leveled Power (dBm) - Option 210, 410

| Description | Specification | | Typical | |
|--------------------|-------------------|-------------------|-------------------|-------------------|
| | Port 1, Port 3 | Port 2, Port 4 | Port 1, Port 3 | Port 2, Port 4 |
| 10 MHz to 50 MHz | 4 | 4 | 14 | 11 |
| 50 MHz to 500 MHz | 7 | 7 | 14 | 12 |
| 500 MHz to 1 GHz | 7 | 7 | 14 | 15 |
| 1 GHz to 2 GHz | 7 | 7 | 12 | 14 |
| 2 GHz to 3.2 GHz | 4 | 7 | 11 | 12 |
| 3.2 GHz to 10 GHz | 7 | 7 | 13 | 13 |
| 10 GHz to 13.5 GHz | 6 | 6 | 12 | 10 |
| 13.5 GHz to 16 GHz | 6 | 6 | 13 | 12 |
| 16 GHz to 19 GHz | 5 | 5 | 11 | 11 |
| 19 GHz to 20 GHz | 5 | 5 | 11 | 11 |
| 20 GHz to 24 GHz | 5 | 5 | 10 | 10 |
| 24 GHz to 26.5 GHz | 5 | 5 | 9 | 9 |
| 26.5 GHz to 30 GHz | 4 | 4 | 9 | 9 |
| 30 GHz to 32 GHz | 3 | 3 | 8 | 8 |
| 32 GHz to 35 GHz | 4 | 4 | 9 | 9 |
| 35 GHz to 40 GHz | -1 | -1 | 7 | 7 |
| 40 GHz to 43.5 GHz | 5 | 5 | 6 | 6 |
| 43.5 GHz to 50 GHz | 5 | 5 | 6 | 7 |
| 50 GHz to 60 GHz | 5 | 5 | 6 | 7 |
| 60 GHz to 64 GHz | 5 | 5 | 6 | 7 |
| 64 GHz to 67 GHz | 5 | 5 | 7 | 8 |
| 67 GHz to 70 GHz | -- | -- | 7 | 8 |

Table 6. Power Level Accuracy (dB) at Nominal Power¹, Option 210, 410

| Description | Specification | Typical |
|--------------------|---------------|---------|
| 10 MHz to 50 MHz | +/- 1.8 | +/- 0.4 |
| 50 MHz to 1 GHz | +/- 1.0 | +/- 0.4 |
| 1 GHz to 3.2 GHz | +/- 1.0 | +/- 0.2 |
| 3.2 GHz to 20 GHz | +/- 2.0 | +/- 0.4 |
| 20 GHz to 26.5 GHz | +/- 2.2 | +/- 0.4 |
| 26.5 GHz to 40 GHz | +/- 3.0 | +/- 0.5 |
| 40 GHz to 43.5 GHz | +/- 3.0 | +/- 0.3 |
| 43.5 GHz to 50 GHz | +/- 3.0 | +/- 0.5 |
| 50 GHz to 60 GHz | +/- 3.5 | +/- 0.6 |
| 60 GHz to 67 GHz | +/- 4.0 | +/- 0.7 |
| 67 GHz to 70 GHz | -- | +/- 1.0 |

¹ Level accuracy at power other than nominal power, Power Level Accuracy (dB) at Nominal Power + Power Level Linearity (dB).

Table 7a. Power Level Linearity¹ (dB), Option 210, 410 - Specification

| Description | Specification | | |
|------------------|---|---|--|
| | Port 1 or 3 ² -25dBm ≤ P < -20dBm | Port 1 or 3 ² -20dBm ≤ P < -15dBm | Port 1 or 3 ² P ≥ -15dBm |
| 10 MHz to 50 MHz | +/-2.7 | +/-1.7 | +/-1.5 |
| 50 MHz to 67 GHz | +/-1.7 | +/-1.5 | +/-1.5 |

¹ Referenced to nominal power.

² Either port can be used as the source port.

Table 7b. Power Level Linearity¹ (dB), Option 210, 410 - Specification

| Description | Specification | | |
|--------------------|---|---|--|
| | Port 2 or 4 ² -25dBm ≤ P < -20dBm | Port 2 or 4 ² -20dBm ≤ P < -15dBm | Port 2 or 4 ² P ≥ -15dBm |
| 10 MHz to 50 MHz | +/-3.5 | +/-1.7 | +/-1.5 |
| 50 MHz to 500 MHz | +/-2.7 | +/-1.5 | +/-1.5 |
| 500 MHz to 3.2 GHz | +/-2.5 | +/-1.5 | +/-1.5 |
| 3.2 GHz to 67 GHz | +/-1.5 | +/-1.5 | +/-1.5 |

¹ Referenced to nominal power.

² Either port can be used as the source port.

Table 8. Power Sweep Range (dB) – Option 210, 410

| Description | Specification | | Typical | |
|--------------------|-------------------|-------------------|-------------------|-------------------|
| | Port 1, Port 3 | Port 2, Port 4 | Port 1, Port 3 | Port 2, Port 4 |
| 10 MHz to 50 MHz | 31 | 31 | 41 | 38 |
| 50 MHz to 500 MHz | 32 | 32 | 41 | 39 |
| 500 MHz to 1 GHz | 32 | 32 | 41 | 42 |
| 1 GHz to 2 GHz | 32 | 32 | 39 | 41 |
| 2 GHz to 3.2 GHz | 29 | 32 | 38 | 39 |
| 3.2 GHz to 10 GHz | 32 | 32 | 40 | 40 |
| 10 GHz to 13.5 GHz | 31 | 31 | 39 | 37 |
| 13.5 GHz to 16 GHz | 31 | 31 | 40 | 39 |
| 16 GHz to 20 GHz | 30 | 30 | 38 | 38 |
| 20 GHz to 24 GHz | 30 | 30 | 37 | 37 |
| 24 GHz to 26.5 GHz | 30 | 30 | 36 | 36 |
| 26.5 GHz to 30 GHz | 29 | 29 | 36 | 36 |
| 30 GHz to 32 GHz | 28 | 28 | 35 | 35 |
| 32 GHz to 35 GHz | 29 | 29 | 36 | 36 |

| | | | | |
|--------------------|----|----|----|----|
| 35 GHz to 40 GHz | 24 | 24 | 34 | 34 |
| 40 GHz to 43.5 GHz | 30 | 30 | 33 | 33 |
| 43.5 GHz to 64 GHz | 30 | 30 | 33 | 34 |
| 64 GHz to 67 GHz | 30 | 30 | 34 | 35 |
| 67 GHz to 70 GHz | -- | -- | 34 | 35 |

Table 9. Nominal (Preset) Power (dBm)

| Description | Option 210, 410 |
|--------------|-----------------|
| Preset Power | -5 |

Table 10. Power Resolution and Maximum/Minimum Settable Power, Option 210, 410

| Description | Specification (dB) | Typical (dBm) |
|------------------------|--------------------|---------------|
| Power Resolution | 0.01 | -- |
| Maximum Settable Power | -- | 30 |
| Minimum Settable Power | -- | -30 |

Table 11. 2nd and 3rd Harmonics at Max Specified Power (dBc), Option 210, 410

Listed frequency is harmonic frequency; test at max specified power

| Description | Typical |
|--------------------|---------|
| 20 MHz to 4 GHz | -17 |
| 4 GHz to 24 GHz | -20 |
| 24 GHz to 27 GHz | -21 |
| 27 GHz to 40.5 GHz | -32 |
| 40.5 GHz to 67 GHz | -60 |
| 67 GHz to 70 GHz | -60 |

Table 12. Non-Harmonic Spurs at Nominal Power (dBc), Option 210, 410 - Typical

| Description | Based on 8kHz offset Frac-N | Based on 100kHz offset Frac-N |
|-------------------|-----------------------------|-------------------------------|
| 10 MHz to 500 MHz | -50 | -50 |
| 500 MHz to 2 GHz | -60 | -42 |
| 2 GHz to 4 GHz | -57 | -45 |
| 4 GHz to 8 GHz | -51 | -39 |
| 8 GHz to 16 GHz | -45 | -33 |
| 16 GHz to 32 GHz | -39 | -27 |
| 32 GHz to 64 GHz | -33 | -21 |
| 64 GHz to 70 GHz | -27 | -15 |

Table 13. Phase Noise (dBc/Hz), Option 210, 410 - Typical

| Description | 1 kHz Offset | 10 kHz Offset | 100 kHz Offset | 1 MHz Offset |
|------------------|--------------|---------------|----------------|--------------|
| 10 MHz to 50 MHz | -100 | -95 | -95 | -120 |
| 50 MHz to 1 GHz | -107 | -117 | -112 | -127 |
| 1 GHz to 2 GHz | -101 | -111 | -106 | -121 |
| 2 GHz to 4 GHz | -95 | -105 | -100 | -115 |
| 4 GHz to 8 GHz | -89 | -99 | -94 | -109 |
| 8 GHz to 16 GHz | -83 | -93 | -88 | -103 |
| 16 GHz to 32 GHz | -77 | -87 | -82 | -97 |
| 32 GHz to 64 GHz | -71 | -81 | -76 | -91 |
| 64 GHz to 70 GHz | -65 | -75 | -70 | -85 |

Test Port Input

Table 14. Test Port Noise Floor (dBm) @ 10 Hz IFBW, Option 210, 410

Total average (rms) noise power calculated as the mean value of a linear magnitude trace expressed in dBm. May typically be degraded at particular frequencies below 500 MHz due to spurious receiver residuals.

| Description | Specification | Typical |
|--------------------|---------------|---------|
| 10 MHz to 50 MHz | -70 | -76 |
| 50 MHz to 100 MHz | -92 | -97 |
| 100 MHz to 500 MHz | -101 | -106 |
| 500 MHz to 1 GHz | -110 | -115 |
| 1 GHz to 10 GHz | -114 | -119 |
| 10 GHz to 13.5 GHz | -114 | -120 |
| 13.5 GHz to 24 GHz | -116 | -121 |
| 24 GHz to 26.5 GHz | -117 | -121 |
| 26.5 GHz to 35 GHz | -106 | -112 |
| 35 GHz to 40 GHz | -104 | -110 |
| 40 GHz to 50 GHz | -101 | -108 |
| 50 GHz to 60 GHz | -101 | -107 |
| 60 GHz to 67 GHz | -101 | -108 |
| 67 GHz to 70 GHz | -- | -106 |

Table 15. 0.1 dB Receiver Compression at Test Port (dBm), Option 210, 410

| Description | Typical |
|-------------------|---------|
| 10 MHz to 100 MHz | 15 |
| 100 MHz to 30 GHz | 12 |
| 30 GHz to 67 GHz | 11 |

Table 16. Receiver Compression at Test Port Power - Specification

| Description | Test Port Power (dBm) | Receiver Compression | |
|--------------------------------|-----------------------|----------------------|-----------------|
| | Option 210, 410 | Magnitude (dB) | Phase (degrees) |
| 10 MHz to 500 MHz ¹ | -- | -- | -- |
| 500 MHz to 16 GHz | 8 | 0.08 | 0.55 |
| 16 GHz to 20 GHz | 8 | 0.08 | 0.60 |
| 20 GHz to 26.5 GHz | 8 | 0.09 | 0.60 |
| 26.5 GHz to 30 GHz | 8 | 0.10 | 0.75 |
| 30 GHz to 35 GHz | 5 | 0.10 | 0.65 |
| 35 GHz to 40 GHz | 3 | 0.13 | 0.70 |
| 40 GHz to 43.5 GHz | 2 | 0.13 | 0.70 |
| 43.5 GHz to 50 GHz | 2 | 0.13 | 0.8 |
| 50 GHz to 67 GHz | 0 | 0.13 | 1.0 |

¹Test port receiver compression at specified input levels below 500 MHz due to coupler roll off in this frequency range.

Table 17. N5227A Trace Noise Magnitude (dB rms)

Ratioed measurement, nominal power at test port.

| Description | Specification | Typical | | |
|--------------------|---------------|------------|--------------|--------------|
| | 1 kHz IFBW | 1 kHz IFBW | 100 kHz IFBW | 600 kHz IFBW |
| 10 MHz to 50 MHz | 0.05 | 0.0177 | 0.173 | 0.416 |
| 50 MHz to 100 MHz | 0.004 | 0.0012 | 0.012 | 0.029 |
| 100 MHz to 500 MHz | 0.002 | 0.0006 | 0.006 | 0.014 |
| 500 MHz to 1 GHz | 0.002 | 0.0004 | 0.003 | 0.006 |
| 1 GHz to 26.5 GHz | 0.002 | 0.0005 | 0.002 | 0.005 |
| 26.5 GHz to 50 GHz | 0.003 | 0.0006 | 0.005 | 0.012 |
| 50 GHz to 67 GHz | 0.003 | 0.0007 | 0.006 | 0.013 |
| 67 GHz to 70 GHz | -- | 0.0010 | 0.007 | 0.016 |

Table 18. N5227A Trace Noise Phase (deg rms)

Ratioed measurement, nominal power at test port.

| Description | Specification | Typical | | |
|----------------------|---------------|------------|--------------|--------------|
| | 1 kHz IFBW | 1 kHz IFBW | 100 kHz IFBW | 600 kHz IFBW |
| 10 MHz to 50 MHz | 0.400 | 0.1228 | 1.205 | 2.928 |
| 50 MHz to 100 MHz | 0.020 | 0.0083 | 0.080 | 0.196 |
| 100 MHz to 500 MHz | 0.020 | 0.0040 | 0.037 | 0.097 |
| 500 MHz to 1 GHz | 0.020 | 0.0017 | 0.015 | 0.037 |
| 1 GHz to 26.5 GHz | 0.020 | 0.0075 | 0.015 | 0.031 |
| 26.5 GHz to 43.5 GHz | 0.030 | 0.0125 | 0.040 | 0.091 |
| 43.5 GHz to 50 GHz | 0.035 | 0.0149 | 0.040 | 0.092 |
| 50 GHz to 67 GHz | 0.045 | 0.0200 | 0.048 | 0.110 |
| 67 GHz to 70 GHz | -- | 0.0213 | 0.050 | 0.119 |

Table 19. Reference Level Magnitude, Option 210, 410 - Specification

| Description | Magnitude (dB) | Phase (degrees) |
|-------------|----------------|-----------------|
| Range | +/- 500 | +/- 500 |
| Resolution | 0.001 | 0.01 |

Table 20. Stability vs. Temperature, Option 210, 410 - Typical

| Description | Magnitude (dB/°C) | Phase (°/°C) |
|-------------------|-------------------|--------------|
| 10 MHz to 50 MHz | 0.03 | 0.400 |
| 50 MHz to 3.2 GHz | 0.01 | 0.100 |
| 3.2 GHz to 20 GHz | 0.01 | 0.200 |
| 20 GHz to 32 GHz | 0.01 | 0.300 |
| 32 GHz to 35 GHz | 0.02 | 0.400 |
| 35 GHz to 50 GHz | 0.02 | 0.400 |
| 50 GHz to 67 GHz | 0.03 | 0.600 |
| 67 GHz to 70 GHz | 0.06 | 1.200 |

Table 21. Stability vs. Time, Option 210, 410 – Specification

The specifications below are observations of the maximum drift performance over +/- 0.5 °C and a period of 24 hours subsequent to a 48 hours warm up period, with ideal load for reflections and ideal thru for transmission measurements.

| Description | Magnitude (dB/24 hours) | | |
|--------------------------------|-------------------------|--------------------|--|
| | S11, S22, S33, S44 | S21, S12, S43, S34 | S31, S13, S41, S14, S42, S24, S32, S23 |
| 10 MHz to 12 MHz ¹ | -52 | 0.025 | 0.025 |
| 12 MHz to 500 MHz ¹ | -60 | 0.013 | 0.018 |
| 500 MHz to 10 GHz | -65 | 0.010 | 0.014 |
| 10 GHz to 20 GHz | -65 | 0.017 | 0.024 |
| 20 GHz to 26.5 GHz | -65 | 0.024 | 0.034 |
| 26.5 GHz to 32 GHz | -60 | 0.028 | 0.040 |
| 32 GHz to 40 GHz | -60 | 0.036 | 0.051 |
| 40 GHz to 43.5 GHz | -60 | 0.037 | 0.052 |
| 43.5 GHz to 50 GHz | -60 | 0.043 | 0.061 |
| 50 GHz to 60 GHz | -60 | 0.055 | 0.078 |
| 60 GHz to 64 GHz | -60 | 0.055 | 0.080 |
| 64 GHz to 67 GHz | -60 | 0.061 | 0.086 |

¹ Performance may be degraded at frequencies below 500 MHz due to spurious receiver residuals.

Table 22. Damage Input Level, Option 210, 410

| Description | RF (dBm) | DC (V) |
|-------------|----------|--------|
| N5227A | 27 | 40 |

Dynamic Accuracy

Dynamic accuracy is verified with the following measurements:

Compression over frequency

IF linearity at a single frequency of 1.998765GHz using a reference level of -20 dBm for an input power range of 0 to -60 dBm. For values below -60 dBm, refer to [VNA Receiver Dynamic Accuracy Specifications and Uncertainties](#)

Table 23. N5227A Dynamic Accuracy

N5227A Dynamic Accuracy, 10 MHz - Specification

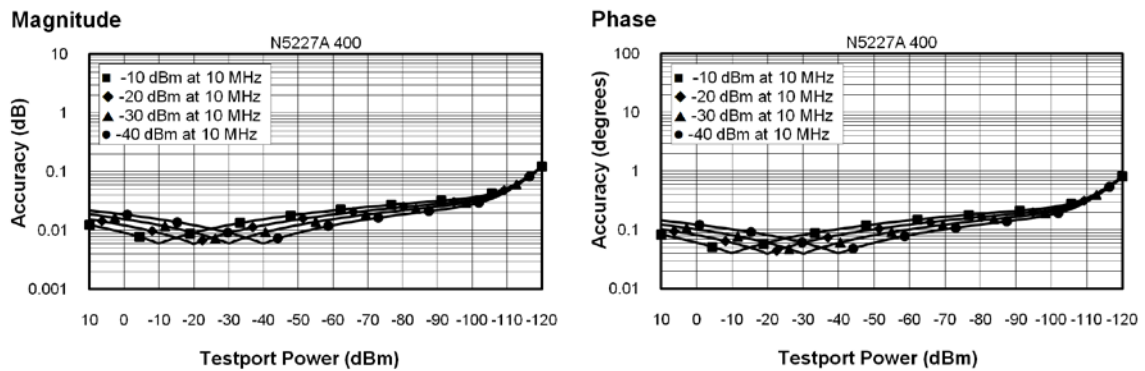

N5227A Dynamic Accuracy, 50 MHz - Specification

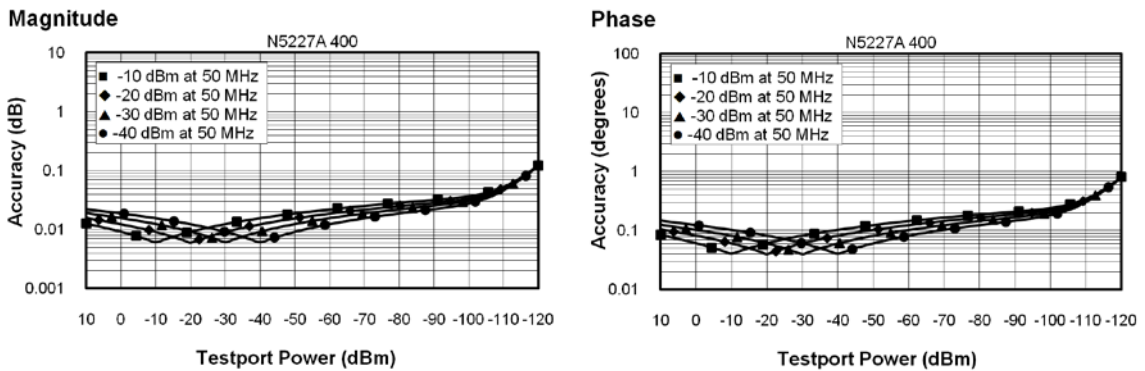

N5227A Dynamic Accuracy, 500 MHz - Specification

Magnitude

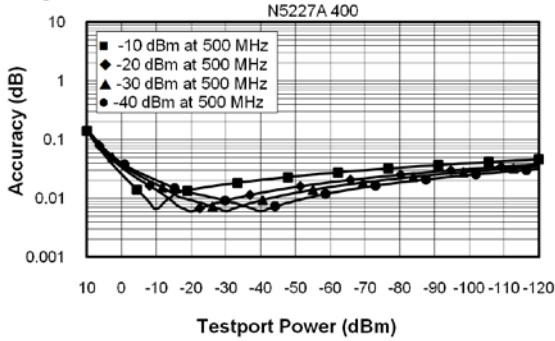

Phase

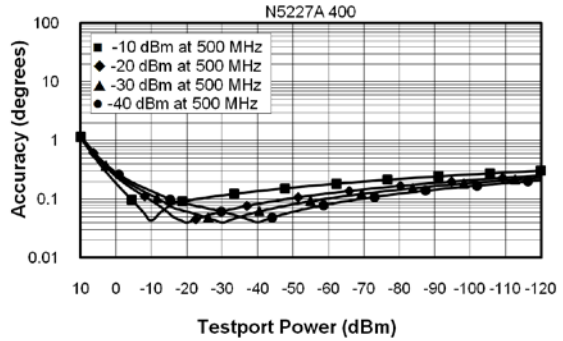

N5227A Dynamic Accuracy, 1 GHz - Specification

Magnitude

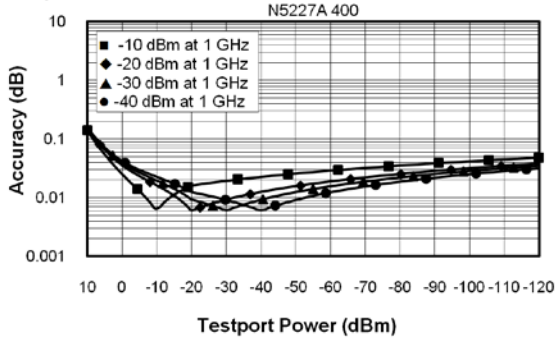

Phase

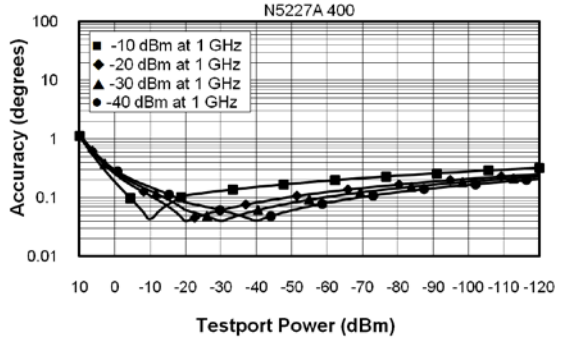

N5227A Dynamic Accuracy, 2 GHz - Specification

Magnitude

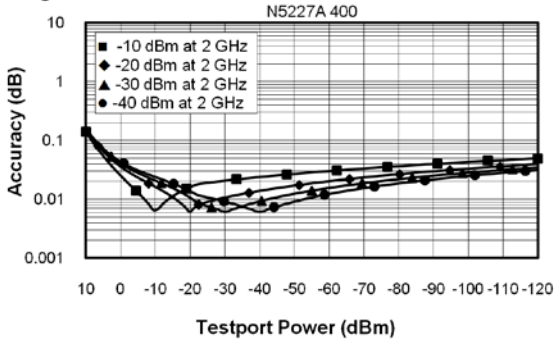

Phase

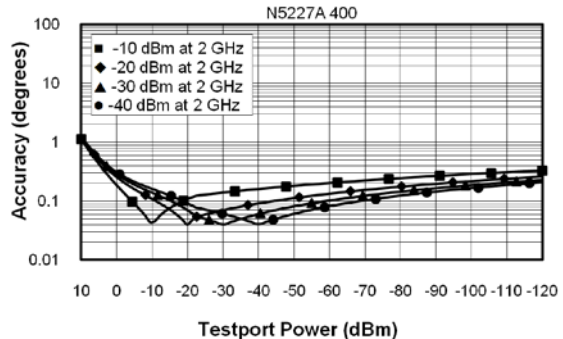

N5227A Dynamic Accuracy, 20 GHz - Specification

Magnitude

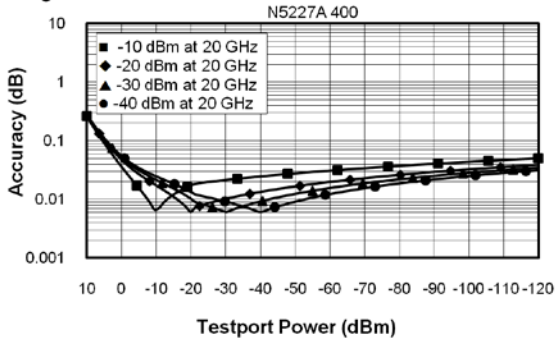

Phase

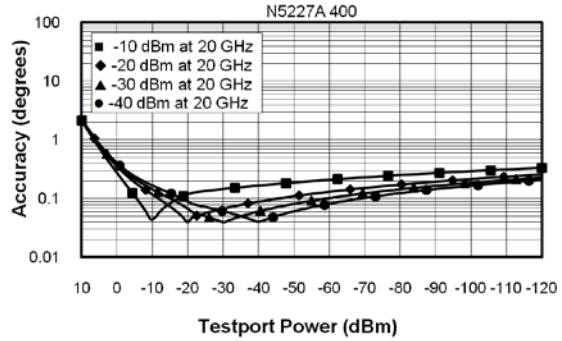

N5227A Dynamic Accuracy, 26.5 GHz - Specification

Magnitude

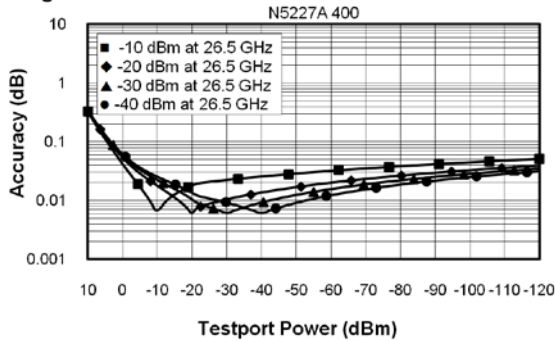

Phase

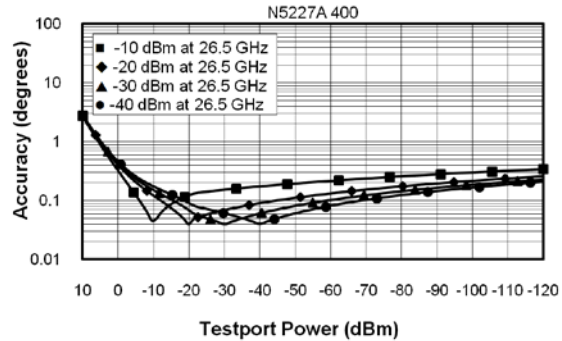

N5227A Dynamic Accuracy, 35 GHz - Specification

Magnitude

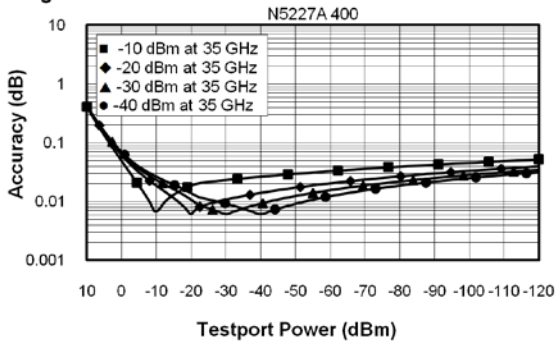

Phase

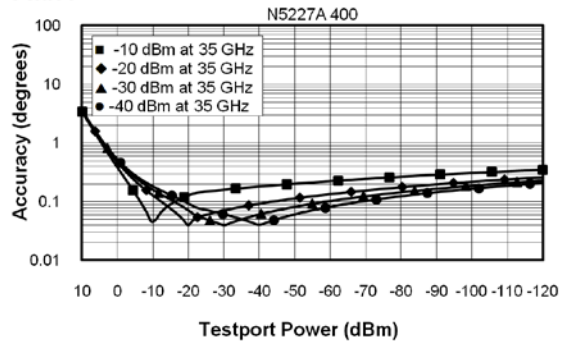

N5227A Dynamic Accuracy, 40 GHz - Specification

Magnitude

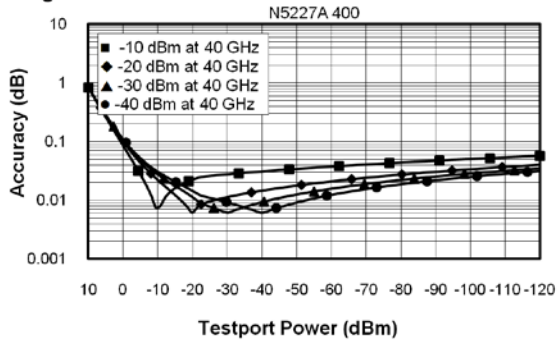

Phase

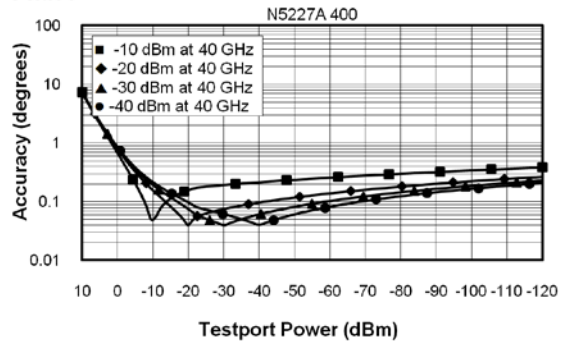

N5227A Dynamic Accuracy, 50 GHz - Specification

Magnitude

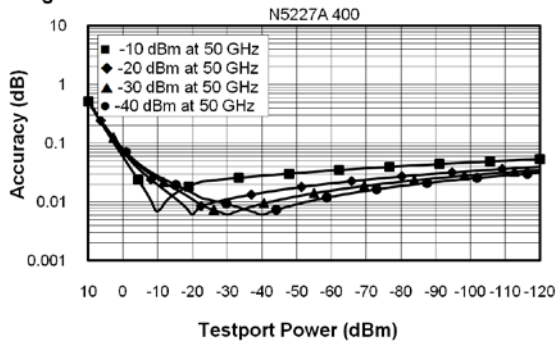

Phase

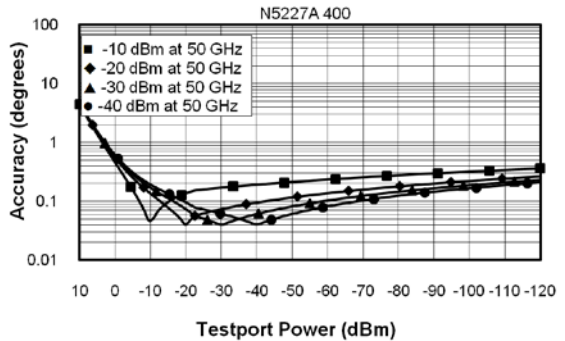

N5227A Dynamic Accuracy, 60 GHz - Specification

Magnitude

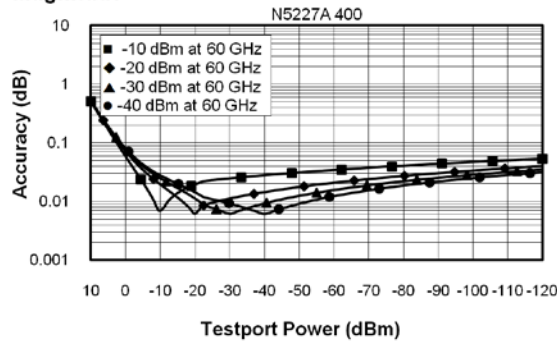

Phase

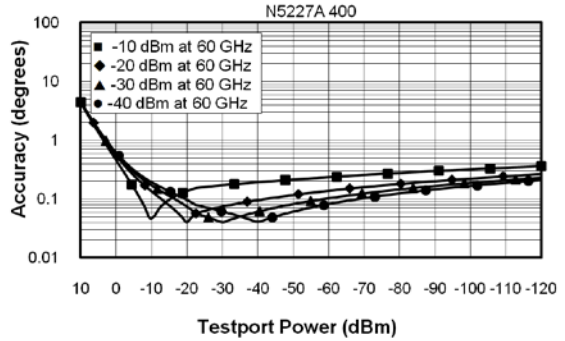

N5227A Dynamic Accuracy, 67 GHz - Specification

Magnitude

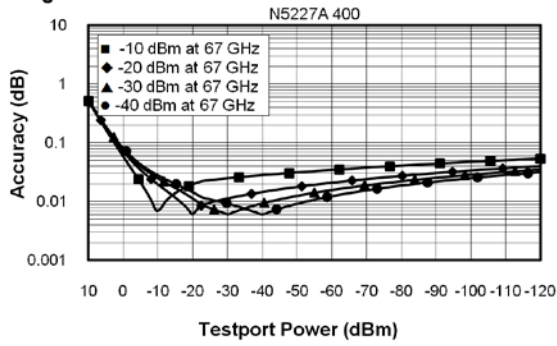

Phase

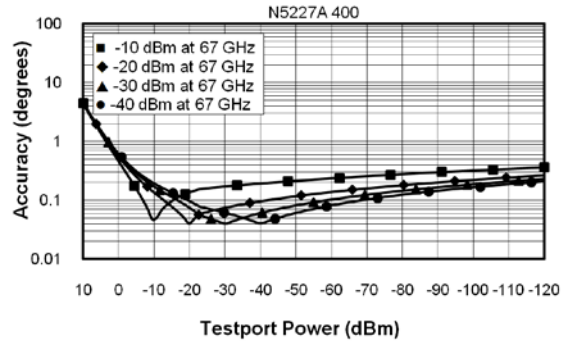

Table 24. Group Delay - Typical

Group delay is computed by measuring the phase change within a specified frequency step (determined by the frequency span and the number of points per sweep). In general, the following formula can be used to determine the accuracy, in seconds, of specific group delay measurement:

$$\pm \text{Phase Accuracy (deg)} / [360 \times \text{Aperture (Hz)}]$$

Depending on the aperture and device length, the phase accuracy used is either incremental phase accuracy or worst-case phase accuracy

| Description | Typical Performance |
|-----------------------|--|
| Aperture (selectable) | (frequency span)/(number of points -1) |
| Maximum Aperture | 20% of frequency span |
| Range | 0.5 x (1/minimum aperture) |
| Maximum Delay | Limited to measuring no more than 180° of phase change within the minimum aperture.) |

The following graph shows characteristic group delay accuracy with full 2-port calibration and a 10 Hz IF bandwidth. Insertion loss is assumed to be < 2 dB and electrical length to be ten meters.

For any S_{ij} Group Delay measurement, $S_{ii} = 0$, $S_{ij} = 1$, $S_{ji} = 0$, $S_{kl} = 0$ for all $kl \neq ij$

Group Delay (Typical)

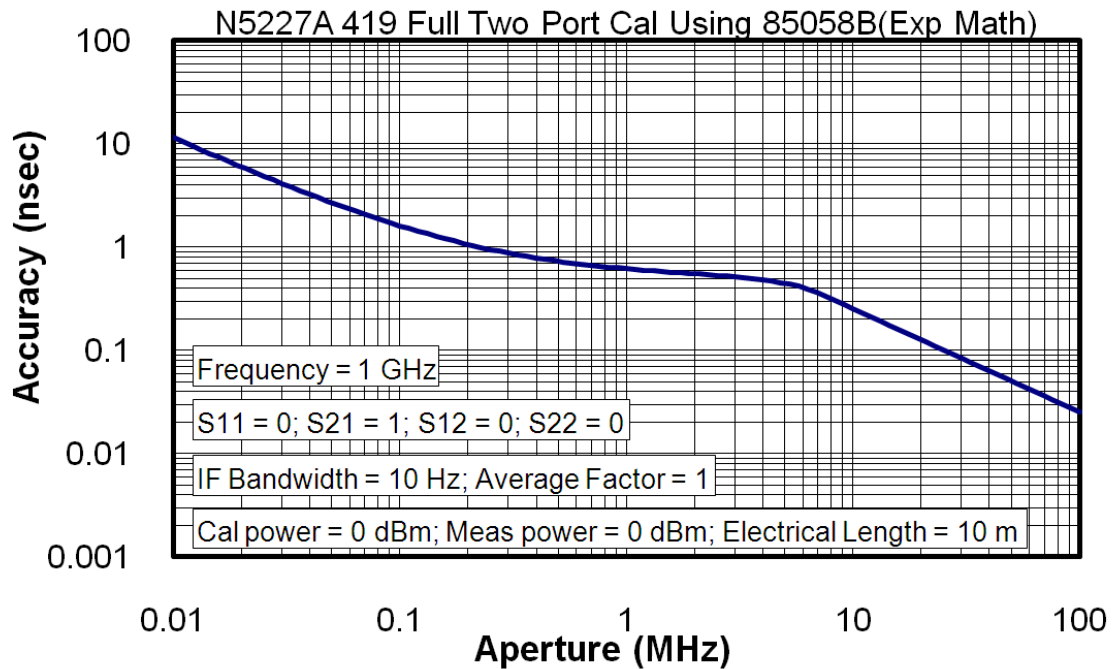

General Information

- [Miscellaneous Information](#)
- [Front Panel](#)
- [Rear Panel](#)
- [Environment and Dimensions](#)

Table 25. Miscellaneous Information

| Description | Supplemental Information |
|---------------------------|---|
| System IF Bandwidth Range | 1 Hz to 15 MHz, nominal |
| CPU | Intel 2.0 GHz Core i7. <div style="background-color: #cccccc; padding: 2px; display: inline-block; margin-bottom: 5px;">NOTE</div> Some instruments may have a different CPU. For the latest information on CPUs and associated hard drives, visit: http://na.support.keysight.com/pna/hdnumbers.html |
| LXI | Class C |

Table 26. Front Panel Information, Option 210, 410

| Description | Typical Performance |
|---|---|
| RF Connectors | |
| Type | 1.85 mm (male), 50 ohm, (nominal) |
| Center Pin Recession | 0.002 in. (characteristic) |
| USB 2.0 Ports - Master (4 ports) | |
| Standard | Compatible with USB 2.0 |
| Connector | USB Type-A female |
| Display | |
| Size | 26.3 cm (10.4 in) diagonal color active matrix LCD; 1024 (horizontal) X 768 (vertical) resolution |
| Refresh Rate | Vertical 60 Hz; Horizontal 46.08 kHz |
| Pixels | Any of the following would cause a display to be considered faulty: <ul style="list-style-type: none"> · A complete row or column consists of “stuck” or “dark” pixels. · More than six “stuck on” pixels (but not more than three green) or more than 0.002% of the total pixels are within the LCD specifications. · More than twelve “dark” pixels (but no more than seven of the same color) or more than 0.004% of the total pixels are within the LCD specifications. · Two or more consecutive "stuck on" pixels or three or more consecutive "dark" pixel (but no more than one set of two consecutive dark pixels) · “Stuck on” “dark” pixels are less than 6.5 mm apart (excluding consecutive pixels) |

Table 26. (Continued) Front Panel Information, Option 210, 410

| Description | Typical Performance |
|---------------------------|-------------------------------------|
| Display Range | |
| Magnitude | +/-2500 dB (at 500 dB/div), max |
| Phase | +/-2500° (at 500 dB/div), max |
| Polar | 10 pUnits, min 10,000 Units, max |
| Display Resolution | |
| Magnitude | 0.001 dB/div, min |
| Phase | 0.01°/div, min |
| Marker Resolution | |
| Magnitude | 0.001 dB, min |
| Phase | 0.01°, min |
| Polar | 10 pUnit, min |

Table 27. Rear Panel Information, Option 210, 410

| Description | Typical Performance |
|-----------------------------|--------------------------|
| 10 MHz Reference In | |
| Connector | BNC, female |
| Input Frequency | 10 MHz ± 10 ppm |
| Input Level | -15 dBm to +20 dBm |
| Input Impedance | 200 Ω, nom. |
| 10 MHz Reference Out | |
| Connector | BNC, female |
| Output Frequency | 10 MHz ± 1 ppm |
| Signal Type | Sine Wave |
| Output Level | +10 dBm ± 4 dB into 50 Ω |
| Output Impedance | 50 Ω, nominal |
| Harmonics | <-40 dBc, typical |

Table 27. (Continued) Rear Panel Information, Option 210, 410

| Description | Typical Performance |
|--|--|
| External IF Inputs | |
| Function | Allows use of external IF signals from remote mixers, bypassing the PNA's first converters |
| Connectors | SMA (female); A, B, C, D, R (4-port); A, B, R1, R2 (2-port) |
| Input Frequency | |
| Normal IF path | RF < 53 MHz: IF = 826.446 KHz RF >= 53 MHz: IF = 7.438 MHz |
| Narrowband IF path | IF = 10.70 MHz |
| Input Impedance | 50 Ω |
| RF Damage Level | +23 dBm |
| DC Damage Level | 5.5 VDC |
| 0.1 dB Compression Point | |
| Normal IF path | -9.0 dBm at 7.438 MHz |
| Narrowband IF path | -17 dBm at 10.70 MHz |
| Pulse Inputs (IF Gates) | |
| Function | Internal receiver gates used for point-in-pulse and pulse-profile measurements |
| Connectors | 15-pin mini D-sub |
| Input Impedance | 1 K Ohm |
| Minimum Pulse Width, Source Modulators | 33 ns |
| Minimum Pulse Width, Receiver Gates | 20 ns |
| DC Damage Level | 5.5 VDC |
| Drive Voltage | 0 V (off), +3.3 V (on), nominal |
| RF Pulse Modulator Input (Source Modulator) | |
| On/Off Ratio | |
| 10 MHz to 3.2 GHz | -64 |
| 3.2 GHz to 67 GHz | -80 |
| Pulse Period | |
| Minimum | 33 ns |
| Maximum | 70 s |

Table 27. (Continued) Rear Panel Information, Option 210, 410

| Description | Typical Performance | |
|--|---|----------------------------|
| Pulse Outputs | | |
| Voltage (TTL) | High: 3.3V to 3.5V Low: <1V | |
| Impedance | 50 Ohm | |
| External Test Set Driver | | |
| Function | Used for driving remote mixers | |
| Connections | 3.5 mm (female) | |
| RF Output Frequency Range | 3.2 GHz to 19 GHz | |
| LO Output Frequency Range | 1.76 GHz to 26.5 GHz | |
| Rear Panel LO Power¹ | | |
| | Upper Limit, Typical (dBm) | Lower Limit, Typical (dBm) |
| 1.7 GHz to 16 GHz | 5 | -3 |
| 16 GHz to 21 GHz | 0 | -6 |
| 21 GHz to 26.5 GHz | 4 | -5 |
| Rear Panel RF1/RF2 Power | | |
| | Maximum Output Power, Typical (dBm) | |
| 3.2 GHz to 5 GHz | +3 | |
| 5 GHz to 19 GHz | +8 | |
| VGA Video Output | | |
| Connector | 15-pin mini D-Sub; Drives VGA compatible monitors | |
| Devices Supported | | |
| | Resolutions | |
| Flat Panel (TFT) | 1024 X 768, 800 X 600, 640 X 480 | |
| Flat Panel (DSTN) | 800 X 600, 640 X 480 | |
| CRT Monitor | 1280 X 1024, 1024 X 768, 800 X 600, 640 X 480 | |
| Simultaneous operation of the internal and external displays is allowed, but with 640 X 480 resolution only. If you change resolution, you can only view the external display (internal display will "white out"). | | |

¹ LO output available in full analyzer's frequency range. The power is tested only from 3.2 GHz to 26.5 GHz.

Table 27. (Continued) Rear Panel Information, Option 210, 410

| Description | Typical Performance |
|------------------------|---|
| Trigger Inputs/Outputs | BNC(f), TTL/CMOS compatible |
| Test Set IO | 25-pin D-Sub connector, available for external test set control. |
| Power IO | 9-pin D-Sub, female; analog and digital IO |
| Handler IO | 36-pin parallel I/O port; all input/output signals are default set to negative logic; can be reset to positive logic via GPIB command. |
| GPIB | Two ports - dedicated controller and dedicated talker/listener. 24-pin D-sub (Type D-24), female; compatible with IEEE-488. |
| Parallel Port (LPT1) | 25-pin D-Sub miniature connector, female; provides connection to printers or any other parallel port peripherals |
| USB Ports | Four ports on front panel (all Host) and five ports (four Host and one Device) on rear panel. Type A configuration (eight Host) and Type B configuration (one Device), USB 2.0 compatible. The total current limit for all rear panel USB ports is 2.0 amps. The total current limit for all front panel USB is 0.9 amps. |
| LAN | 10/100BaseT Ethernet, 8-pin configuration; auto selects between the two data rates |
| Line Power | |
| Frequency, Voltage | 50/60/400 Hz for 100 to 120 VAC 50/60 Hz for 220 to 240 VAC |
| | Power supply is auto switching |
| Max | 450 watts |

Table 28. Analyzer Dimensions and Weight

All models are shipped with handles.

| Cabinet Dimensions | Metric (mm) | Imperial (inches) |
|---|-------------|-------------------|
| Height | | |
| Without bottom feet: 1 EIA RU = 6 | 266.1 | 10.5 |
| With bottom feet | 279.1 | 11.0 |
| Width | | |
| Without handles or rack-mount flanges | 425.6 | 16.8 |
| With handles, without rack-mount flanges | 458.7 | 18.1 |
| With handles and rack-mount flanges | 482.9 | 19.0 |
| Depth | | |
| Without front and rear panel hardware | 582.3 | 22.9 |
| With front and rear panel hardware, handles | 649.6 | 25.6 |

¹Electronics Industry Association rack units. 1 RU = 1.75 in.

See detailed PNA dimension drawings at: <http://na.support.keysight.com/pna/PNADimensions.pdf>

| Weight (nominal) | Net | Shipping |
|----------------------------|-----------------|------------------|
| 2-port models (Option 210) | 42.2 kg (93 lb) | 57.6 kg (127 lb) |
| 4-port models (Option 410) | 44.9 kg (99 lb) | 60.3 kg (133 lb) |

Regulatory and Environmental Information

For Regulatory and Environmental information, refer to the PNA Series Installation and Quick Start Guide, located online at <http://literature.cdn.keysight.com/litweb/pdf/E8356-90001.pdf>.

Measurement Throughput Summary

- Typical Cycle Time for Measurement Completion
- Cycle Time vs. IF Bandwidth
- Cycle Time vs. Number of Points
- Data Transfer Time

Cycle time Includes sweep time, retrace time and band-crossing time. Analyzer display turned off with DISPLAY:ENABLE OFF. Add 21 ms for display on. Data for one trace (S₁₁) measurement.

Table 29. Typical Cycle Time (ms) for Measurement Completion, All Models and Options

| Sweep Range | IF Bandwidth | | Number of Points | | | | |
|------------------|--------------|-------------|------------------|------|------|-------|-------|
| | | | 201 | 401 | 1601 | 16001 | 32001 |
| 9 GHz to 10 GHz | 600 kHz | Uncorrected | 6.3 | 7 | 10.9 | 69.5 | 135 |
| | | 2-Port cal | 18.8 | 20.3 | 30.5 | 152 | 291 |
| | 10 kHz | Uncorrected | 28.1 | 54.7 | 205 | 2003 | 4006 |
| | | 2-Port cal | 67.2 | 117 | 418 | 4028 | 8062 |
| | 1 kHz | Uncorrected | 225 | 444 | 1744 | 17041 | 33853 |
| | | 2-Port cal | 463 | 900 | 3500 | 34100 | 67744 |
| 10 GHz to 20 GHz | 600 kHz | Uncorrected | 19.5 | 20.3 | 25.8 | 79.7 | 141 |
| | | 2-Port cal | 46.9 | 49.2 | 60.2 | 174 | 310 |
| | 10 kHz | Uncorrected | 69.5 | 128 | 259 | 2012 | 4012 |
| | | 2-Port cal | 146 | 264 | 528 | 4041 | 8072 |
| | 1 kHz | Uncorrected | 235 | 459 | 1783 | 17384 | 34538 |
| | | 2-Port cal | 477 | 924 | 3575 | 34788 | 69103 |

Table 30. Typical Cycle Time (ms) for Full-Span Measurement Completion

| 10 MHz to 67 GHz | | Number of Points | | | | |
|------------------|-------------|------------------|------|------|-------|-------|
| IF Bandwidth | | 201 | 401 | 1601 | 16001 | 32001 |
| 600 kHz | Uncorrected | 55.5 | 72.7 | 94.5 | 182 | 248 |
| | 2-Port cal | 117 | 152 | 195 | 374 | 509 |
| 10 kHz | Uncorrected | 89.1 | 153 | 519 | 2219 | 4223 |
| | 2-Port cal | 185 | 313 | 1042 | 4448 | 8462 |
| 1 kHz | Uncorrected | 255 | 483 | 1834 | 17716 | 35172 |
| | 2-Port cal | 515 | 972 | 3675 | 35444 | 70375 |

Table 31. Cycle Time vs. IF Bandwidth - Typical

Applies to the Preset condition (201 points, correction off) except for the following changes:

- CF = 10 GHz
- Span = 100 MHz
- Display off (add 21 ms for display on)

Cycle time includes sweep and retrace time.

| Description | | N5227A |
|-------------------|-----------------|--------------------------------|
| IF Bandwidth (Hz) | Cycle Time (ms) | Trace Noise Magnitude (dB rms) |
| 600,000 | 6.3 | 0.0044 |
| 100,000 | 7 | 0.0021 |
| 30,000 | 10.2 | 0.0011 |
| 10,000 | 29.7 | 0.0007 |
| 3,000 | 71.9 | 0.0006 |
| 1,000 | 223 | 0.0004 |
| 300 | 641 | 0.0004 |
| 100 | 1825 | 0.0003 |
| 30 | 5981 | 0.0003 |
| 10 | 17834 | 0.0003 |
| 3 | 59273 | 0.0003 |

Table 32. Cycle Time vs. Number of Points - Typical

Applies to the Preset condition (correction off) except for the following changes:

- CF = 10 GHz
- Span = 100 MHz
- Display off (add 21 ms for display on)

Cycle time includes sweep and retrace time.

| Description | IF Bandwidth (Hz) | | | |
|------------------|-------------------|--------|--------|--------|
| | 1,000 | 10,000 | 30,000 | 60,000 |
| Number of Points | | | | |
| 3 | 7.8 | 6.3 | 6.3 | 6.3 |
| 11 | 16.4 | 6.3 | 6.3 | 6.3 |
| 51 | 60 | 11 | 6.3 | 6.3 |
| 101 | 114 | 17.2 | 7 | 6.3 |
| 201 | 223 | 29.7 | 9.4 | 6.3 |
| 401 | 437 | 54.7 | 14.9 | 7.1 |
| 801 | 862 | 105 | 25 | 7.8 |
| 1,601 | 1708 | 205 | 46 | 11 |
| 6,401 | 6728 | 805 | 169 | 30.5 |
| 16,001 | 16672 | 2005 | 417 | 68.8 |
| 32,001 | 33112 | 4006 | 833 | 134 |

Table 33. Data Transfer Time (ms) - Typical

Measured with the analyzer display off.

Values will increase slightly if the analyzer display is on.

| Description | Number of Points | | | | |
|---|------------------|------|------|--------|--------|
| | 201 | 401 | 1601 | 16,001 | 32,001 |
| SCPI over GPIB (Program executed on external PC ²) | | | | | |
| 32-bit floating point | 4.6 | 9.3 | 38 | 352 | 720 |
| 64-bit floating point | 9.4 | 18.8 | 73.4 | 730 | 1455 |
| ASCII | 36.7 | 72.5 | 288 | 2882 | 5762 |
| SCPI over SICL/LAN or TCP/IP Socket¹ (Program executed in the analyzer) | | | | | |
| 32-bit floating point | <1 | <1 | <1 | 1.2 | 2.4 |
| 64-bit floating point | <1 | <1 | <1 | 2.3 | 4.6 |
| ASCII | 2.1 | 4 | 15 | 148 | 295 |
| COM¹ (Program executed in the analyzer) | | | | | |
| 32-bit floating point | <1 | <1 | <1 | <1 | <1 |
| Variant type | <1 | <1 | 1.4 | 12.4 | 25.5 |
| DCOM over LAN¹ (Program executed on external PC) | | | | | |
| 32-bit floating point | <1 | <1 | <1 | 2.3 | 4.4 |
| Variant type | <1 | 1.6 | 5.3 | 52 | 105.5 |

¹ Values are for real and imaginary pairs, with the analyzer display off, using Gigabit Ethernet.

NOTE

Specifications for Recall & Sweep Speed are not provided for the N522xA analyzers.

Test Set Block Diagrams

NOTE

For best readability, use a color printer for printing the following graphics.

Legend

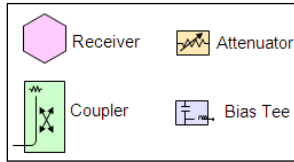

N5227A Option 210 (2-port metrology configuration)

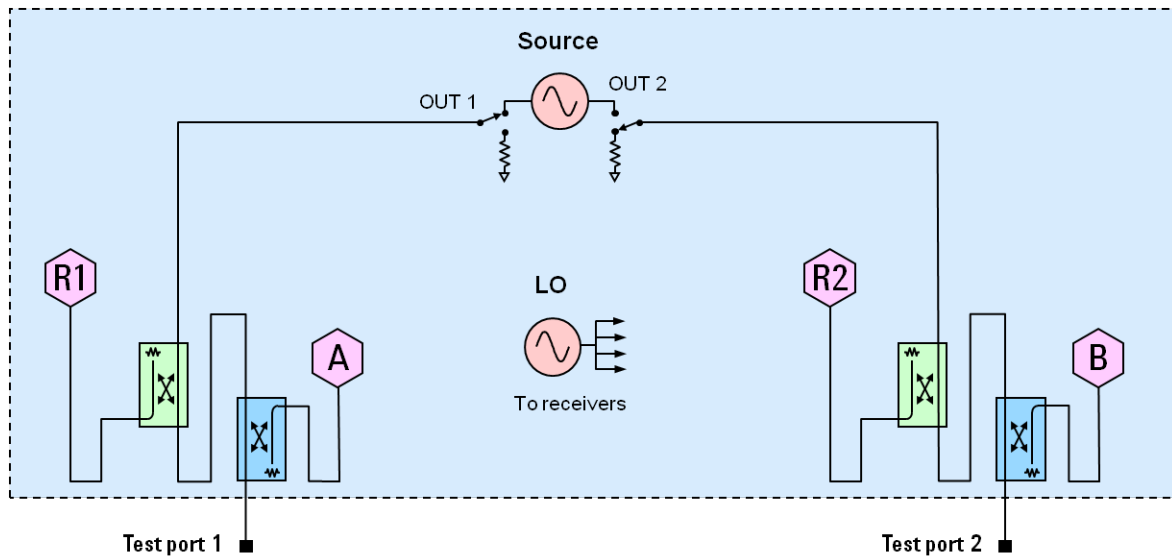

N5227A Option 410 (4-port metrology configuration)

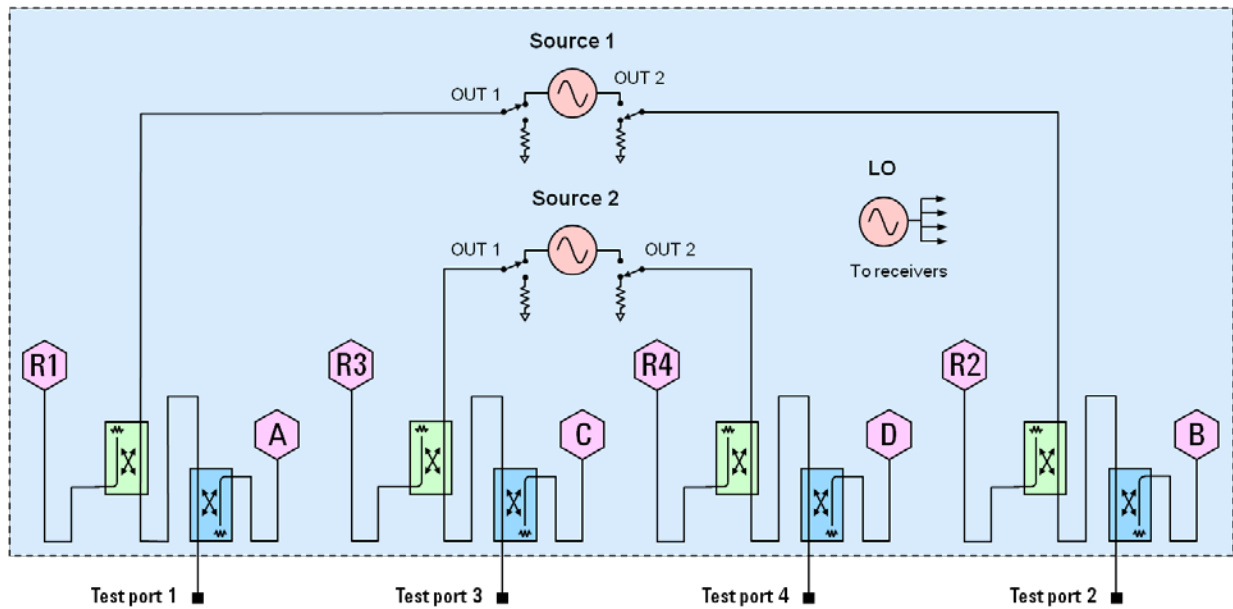

Receiver Block Diagram

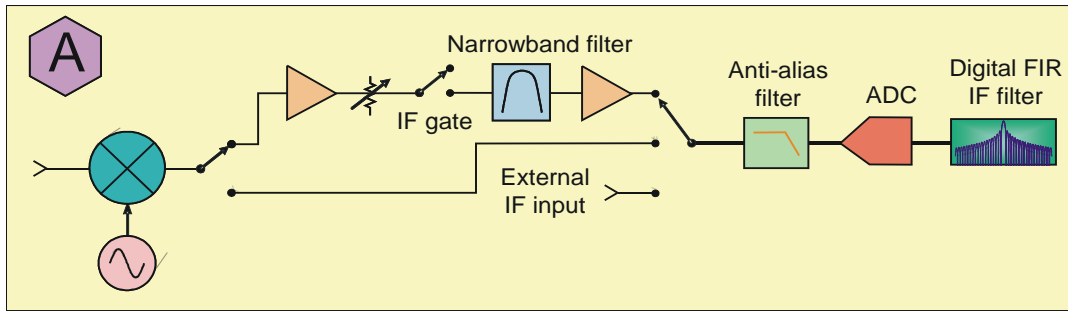



This information is subject to change without notice.
© Keysight Technologies 2014-2015
Print Date: October 12, 2015



N5227-90003

www.keysight.com